



TxIsoRail

ISOLATED TRANSMITTER – USER GUIDE – V1.0x A

1. SPECIFICATIONS

Sensor input: User defined. The supported sensors are listed in **Table 1**, along with their maximum ranges.

Thermocouples: Types J, K, R, S, T, N, E, and B, according to IEC 60584 (ITS-90). Impedance >> 1 MΩ

Pt100: 3-wire connection, Excitation: 180 μA, α = 0.00385, according to IEC 60751 (ITS-90).

For 2-wire Pt100, tie terminals 2 and 3 together.

Voltage: 0 to 50 mVdc, 0 to 10 Vdc. Impedance >> 1 MΩ.

Current: 0 to 20 mA, 4 to 20 mA. Impedance 15.0 Ω (+ 1.9 Vdc).

SENSOR TYPE	RANGE	MINIMUM MEASUREMENT SPAN
Thermocouple K	-150 to 1370 °C / -238 to 2498 °F	100 °C / 212 °F
Thermocouple J	-100 to 760 °C / -148 to 1400 °F	100 °C / 212 °F
Thermocouple R	-50 to 1760 °C / -58 to 3200 °F	400 °C / 752 °F
Thermocouple S	-50 to 1760 °C / -58 to 3200 °F	400 °C / 752 °F
Thermocouple T	-160 to 400 °C / -256 to 752 °F	100 °C / 212 °F
Thermocouple N	-270 to 1300 °C / -454 to 2372 °F	100 °C / 212 °F
Thermocouple E	-90 to 720 °C / -130 to 1328 °F	100 °C / 212 °F
Thermocouple B	500 to 1820 °C / 932 to 3308 °F	400 °C / 752 °F
Pt100	-200 to 600 °C / -328 to 1112 °F	40 °C / 104 °F
Voltage	0 to 50 mV	5 mV
	0 to 10 V *	1 V
Current	0 to 20 mA	2 mA
	4 to 20 mA	2 mA

Table 1 – Transmitter input sensors

* **Note:** 0-10 Vdc input type requires an internal jumper switching.

Response time: < 500 ms

Electrical isolation: 1000 V for 1 minute between input and output.

Maximum load (RL): $RL (max.) = (Vdc - 12) / 0.02 [\Omega]$

Where: Vdc = Power supply voltage

Operating temperature: -40 to 85 °C / -40 to 185 °F

Humidity: 0 to 90 % UR

Electromagnetic compatibility: EN 50081-2, EN 50082-2

Internal protection against polarity inversion.

Cold Junction compensation for thermocouples.

Certifications: CE, UKCA.

1.1 4-20 mA MODEL

Output: 4-20 mA or 20-4 mA current, 2-wire type; linear to input signal.

Output resolution: 0.001 mA (14 bits)

Total accuracy: 0.30 % of maximum range for thermocouples, ±1 °C;

0.20 % of maximum range for Pt100, voltage, and current.

Power supply: 12 to 35 Vdc, voltage applied to the transmitter.

1.2 0-10 VDC MODEL

Output: Voltage 0 to 10 Vdc or 10 to 0 Vdc; linear to input signal.

Output resolution: 0.0006 V (14 bits)

Total accuracy: 0.25 % of maximum range for thermocouples, ±1 °C;

0.15 % of maximum range for Pt100, voltage, and current.

Power supply: 18 to 30 Vdc, voltage applied to the transmitter.

2. CONFIGURATION

When the transmitter is used with the factory setting, no further action is required, and the transmitter is ready to be installed.

When it is necessary to change the configuration of the equipment, you should use **SigNow** software, **TxConfig** software, or **SigNow** app.

To configure the equipment through any of the software, you must connect the **TxConfig** Configuration Interface (purchased from the manufacturer or its authorized representatives) to the USB port of the computer used and run the selected software, as shown in **Figure 1:**



Figure 1 – TxConfig Interface USB connections

To configure the device via **SigNow** app, you need to use an OTG cable with the **TxConfig** Configuration Interface and proceed with the recognition process (see [SMARTPHONE CONNECTIONS](#) chapter).

On **NOVUS** website, you can download the configuration software for free. To install it, simply run the file **SigNowSetup.exe** or the file **TxConfigSetup.exe** and follow the instructions in the installer.

The **SigNow** setup application can be downloaded for free from the **Google Play Store**.

2.1 SOFTWARE AND APP

2.1.1 SIGNOW SOFTWARE

When running the **SigNow** software and connecting to the device, the following screen will appear:

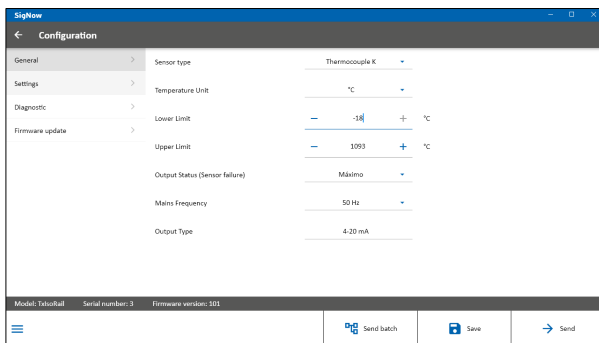

Figure 2 – SigNow configuration screen

The bottom part of the screen displays information about the model, serial number, and firmware version.

The configuration screen is divided into 4 sections: General, Settings, Diagnostics and Firmware Update.

In the General (see above) and Settings screens, you can configure the device by setting values and information for the following parameters:

1. **Sensor Type:** Allows you to select the sensor to be used. See **Table 1**.
2. **Temperature Unit:** Allows you to select the temperature unit to be used.
3. **Lower Limit:** Allows you to define the minimum desired temperature for the configured output type.
4. **Upper Limit:** Allows you to define the maximum desired temperature for the configured output type.
5. **Sensor Failure:** Allows you to establish the output behavior when the transmitter indicates a failure:
Minimum: Output current goes to < 3.6 mA (down-scale), typically used for refrigeration.
Maximum: Output current goes to > 22.0 mA (up-scale), typically used for heating.
6. **Network Frequency:** Allows you the network frequency to be used.
7. **Output Type:** Displays the output type of the equipment, which will change according to the model (**TxIsoRail 4-20 mA** or **TxIsoRail 0-10 Vdc**).
8. **Zero Correction:** Allows you to correct small deviations presented in the transmitter output, such as when changing a sensor.

In the **SigNow** manual, available on **NOVUS** website, you can get more specific information about the buttons and the process of diagnostics and firmware update.

2.1.2 TXCONFIG SOFTWARE

When running the **TxConfig** software and connecting to the device, the following screen will appear:

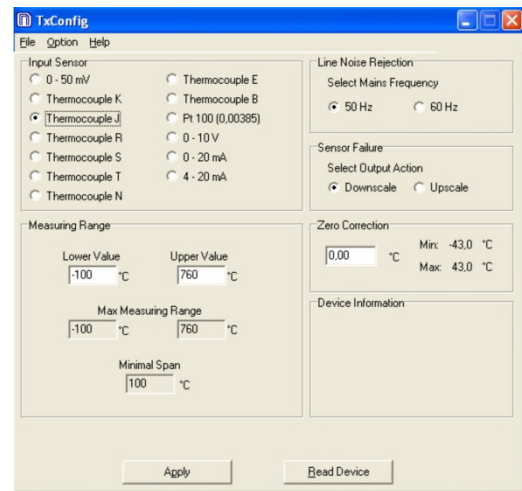

Figure 3 – TxConfig software main screen

The fields in the screen mean:

1. **Input Sensor:** Allows you to select the sensor to be used. See **Table 1**.
2. **Measuring Range:** Allows you to define the measurement range of the transmitter, showing a **Lower Limit** value and an **Upper Limit** value.
When configuring the **Lower Limit** with a value higher than the **Upper Limit**, the output current operates from 20 to 4 mA.
The chosen values cannot exceed the **Sensor Range** shown in this same field. It is not possible to set the span narrower than the **Minimum Range** value shown below in this same field. See **Table 1**.
3. **Line Noise Rejection:** Allows you to filter the measurements made by the transmitter, eliminating interferences from the electrical network that feeds the process.
4. **Sensor Failure:** Allows you to establish the output behavior (upscale or downscale) when the transmitter indicates a failure.
5. **Zero Correction:** Allows you to correct small deviations presented in the transmitter output, such as when changing a sensor.
6. **Device Information:** This field shows data that identifies the transmitter, including the model (**TxIsoRail 4-20 mA** or **TxIsoRail 0-10 Vdc**). This information should be sent to the manufacturer in an eventual request for technical assistance.
7. **Apply:** Allows you to send a new configuration to the transmitter.
8. **Read Device:** Allows you to read the configuration present in the connected transmitter. The screen will display the current configuration, which can be changed.

2.1.3 SIGNOW APP

When using an OTG cable and the **TxConfig** Configuration Interface to connect the equipment to your smartphone and run the **SigNow** app (see [SMARTPHONE CONNECTIONS](#) chapter), you must first enable the use of **TxConfig**.

The interface will act as an intermediary for the connection:

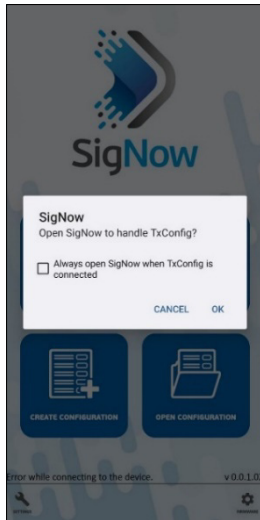

Figure 4 – Using TxConfig

After that, the app will recognize **TxConfig** and show the main screen:

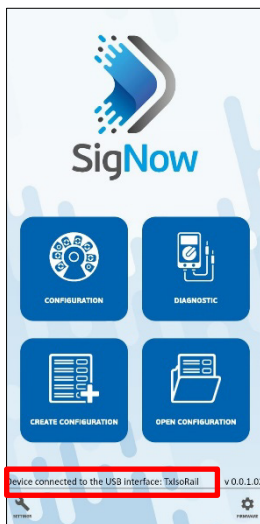

Figure 5 – Main screen

To configure the equipment, just click the **Configuration** button. Then, the app will show the main screen of the **TxIsoRail** Configuration section:

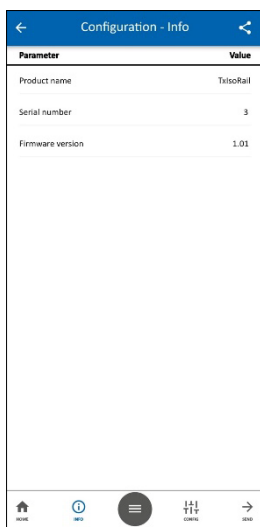

Figure 6 – Information screen

This screen shows information about the equipment, such as name, serial number, and firmware version.

When you open the **Config** section, you can configure the parameters displayed in the [SIGNOW SOFTWARE](#) section.

In the **SigNow** manual, available on **NOVUS** website, you can find more information about the buttons and the diagnostic process.

2.2 FACTORY SETTINGS

If the specific configuration is not defined in the purchase order, the following configuration will be adopted:

- Pt100 input, 0 to 100 °C (32 to 212 °F).
- 60 Hz filtering and upscale (20 mA) output for sensor fail.

2.3 POWER SUPPLY

During configuration, the transmitter needs to be electrically powered. The **TxConfig Interface** itself provides the power supply, but this depends on the computer used.

To ensure constant communication between the transmitter and the computer, an external power supply must be provided.

It is also possible to configure the transmitter by keeping it connected to the process, using energy from the very source that feeds this process (loop). See **Figure 7**.

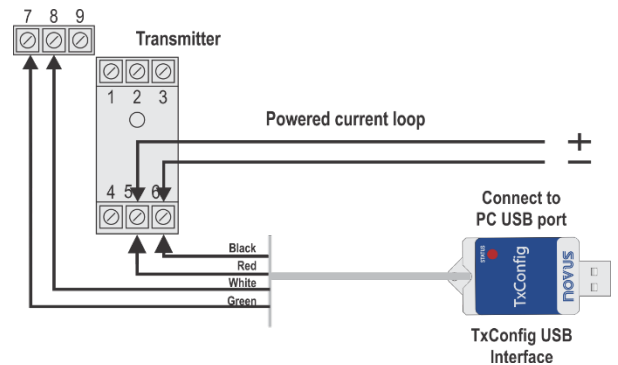

Figure 7 – TxConfig Interface USB connections – Loop powered

The TxConfig Interface has a complex electronic circuit. Do not use any other interface or cable connection to USB. This will damage the product and this damage is not covered under warranty.

3. SMARTPHONE CONNECTIONS

Smartphones with *On the Go* (OTG) technology can be directly connected to the device via the Micro-USB input. Using the **TxConfig** Configuration Interface, it is possible to recognize and configure a **TxIsoRail** by running the **SigNow** app.

To do this, as shown in **Figure 8**, you need to observe how to connect the OTG cable to the equipment:

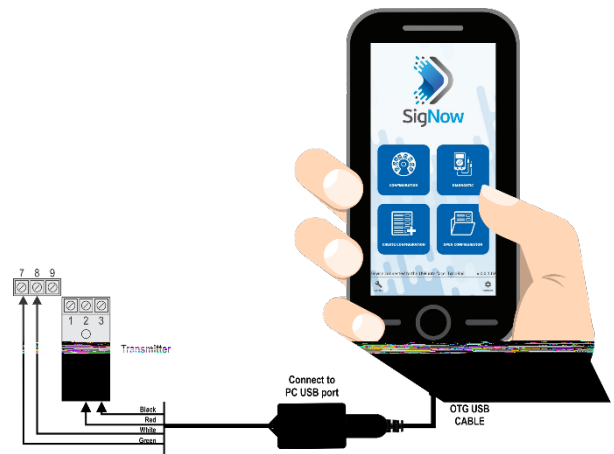

Figure 8 – OTG Cable



Incorrect positioning of the cable tip can cause the equipment not to be recognized by the app.

4. MECHANICAL INSTALLATION

The transmitter is designed to be installed on a 35 mm DIN rail.

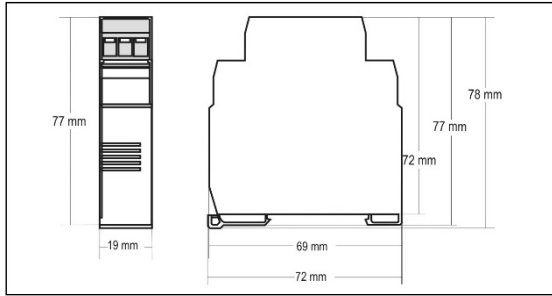

Figure 9 – Transmitter dimensions

5. ELECTRICAL CONNECTIONS

Figure below shows the transmitter connections to the sensor and power supply. Terminals 1, 2, and 3 are used for sensor input.

When using 2-wire Pt100, terminals 2 and 3 shall be tied together.

5.1 4-20 mA MODEL

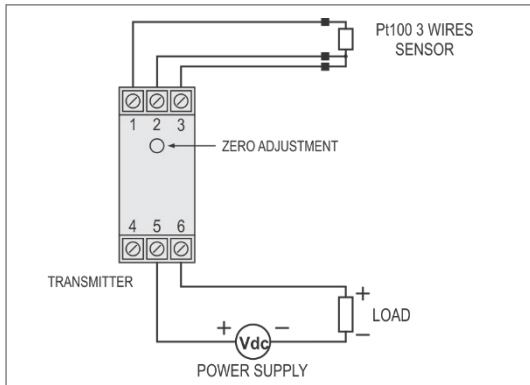

Figure 10 – TxIsoRail 4-20 mA – Pt100

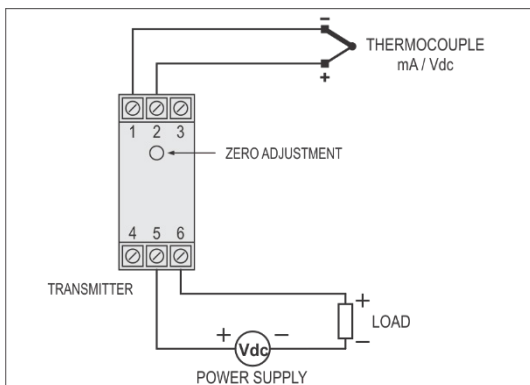

Figure 11 – TxIsoRail 4-20 mA – Thermocouple, mA, Vdc

The **LOAD** represents the input shunt of an instrument measuring the 4-20 current loop.

5.2 0-10 VDC MODEL

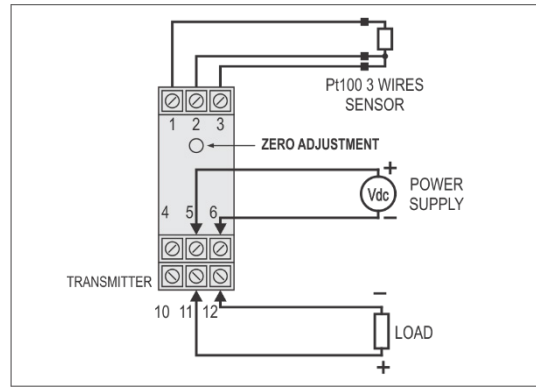

Figure 12 – TxIsoRail 0-10 Vdc – Pt100

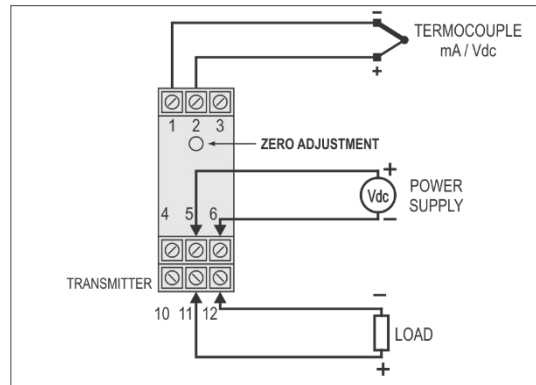

Figure 13 – TxIsoRail 0-10 Vdc – Thermocouple, mA, Vdc

The **LOAD** represents the input shunt of an instrument measuring the 4-20 current loop.

5.3 0-10 VDC INPUT

To use the 0-10 Vdc input type, you must perform a small intervention in the transmitter circuitry. To do so, it is necessary to open the transmitter and change a jumper position. See **Figure 10**.

- For input type 0-10 Vdc, place the jumper in positions 1 and 2.
- For all other input types, place the jumper in positions 2 and 3.

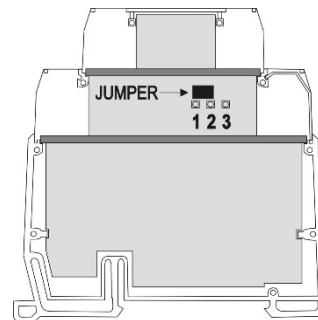

Figure 14 – Jumper position for 0-10 Vdc input

6. OPERATION

The transmitter leaves the factory perfectly calibrated and with standardized sensors. It does not require any adjustment by the user.

When necessary, it is possible to make small corrections to the output signal directly at the transmitter. To do this, simply press the **ZERO** key on the front of the transmitter. To prevent accidental adjustments, this key is located just below the front label. It can be accessed with a small 2 mm diameter tool.

For the **4-20 mA TxIsoRail** model, after holding down the key for two seconds, the output current will increase up to 0.80 mA beyond the starting value. Then it will quickly drop to 0.80 mA below the initial value and start a new rise. You need to monitor the output current and, when the current reaches the desired value, release the key.

For the **0-10 Vdc TxIsoRail** model, after holding down the key for two seconds, the output voltage will increase up to 0.25 V beyond the starting value. Then it will quickly drop to 0.25 V below the initial value and start a new rise. You need to monitor the output voltage and, when the current reaches the desired value, release the key.

These small corrections can also be made using **SigNow** or **TxConfig** software (now in measured units of magnitude) or **SigNow** app.

Even with the equipment connected to the process and operating, the **TxConfig Interface** can be connected to the transmitter. See **Figure 2** or **Figure 3** and the **Zero Correction** fields on the **SigNow** or **TxConfig** software screens.

It is necessary to choose the input type and range that best suits the process. The chosen measurement range must not exceed the maximum range defined for the input type and must not be smaller than the minimum range.

It is important to note that the accuracy of the transmitter is always based on the maximum measurement range of the input type used, even when an intermediate measurement range has been set.

Example:

- The Pt100 sensor has a maximum range of -200 to +600 °C and an overall accuracy of 0.2 %.
- Maximum error: 1.2 °C (0.2 % of 800 °C)
- This error is possible in a wide range such as the maximum (-200 to 600 °C) or in a narrower range defined as 0 to 100 °C.

Note: When checking the transmitter, make sure that the excitation current of Pt100 required by the calibrator used is compatible with the excitation current of Pt100 used in the transmitter: 0.18 mA.

7. WARRANTY

Warranty conditions are available on our website www.novusautomation.com/warranty.