

# ULC HEAT SWITCH-15A

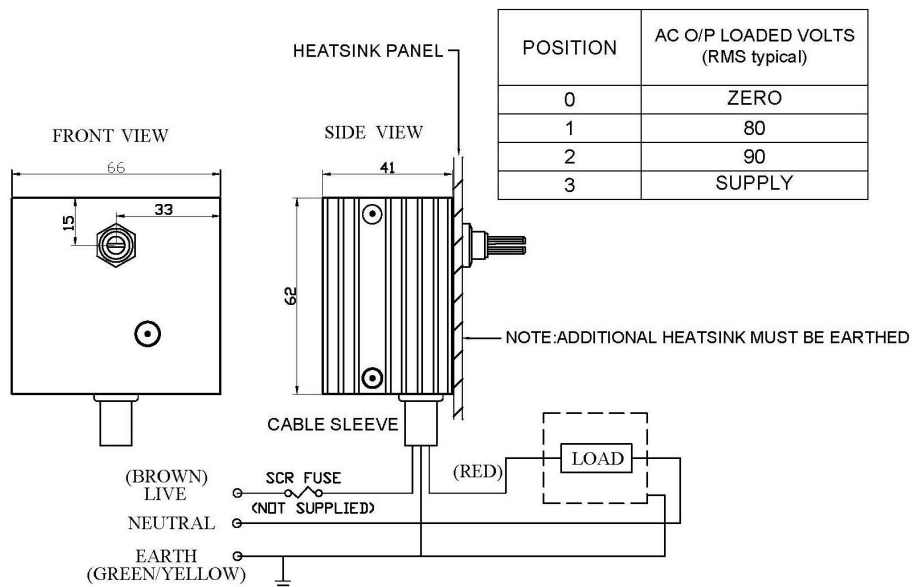

## Electronic Phase Angle Thermal Switch with RFI Suppression



**WARNING**  
LIVE TERMINALS-SWITCH OFF SUPPLY BEFORE COMMENCING ANY SERVICE WORK.  
FOR HEATSINK PANEL MOUNTING  
A 10mm HOLE IS REQUIRED TO ACCEPT MOUNTING BUSH.  
USE HEATSINK COMPOUND FOR EFFECTIVE THERMAL COUPLING.

### Standards

ULC units are suitable for 230V mains and have an integrated three position on and off control switch with wired cables for connection.

The large triac allows the device to handle high inrush currents with a large safety margin in industrial installations. These units contain their own RFI filter network to comply with EMC regulations (Class A).

## Applications

Conventional resistive heating elements, quartz lamps, single phase, series or parallel configurations of the specified voltages,

Current and temperature limits and inductive loads such as, transformers and motors.

## Features

Integrated RFI network (filtering).

Plug in the power connector board.

Single 10mm hole mounting socket.

Designed for maximum heat dissipation.

15A (max) rating (when properly panel mounted)

Supplied with knob and dial

## Installation

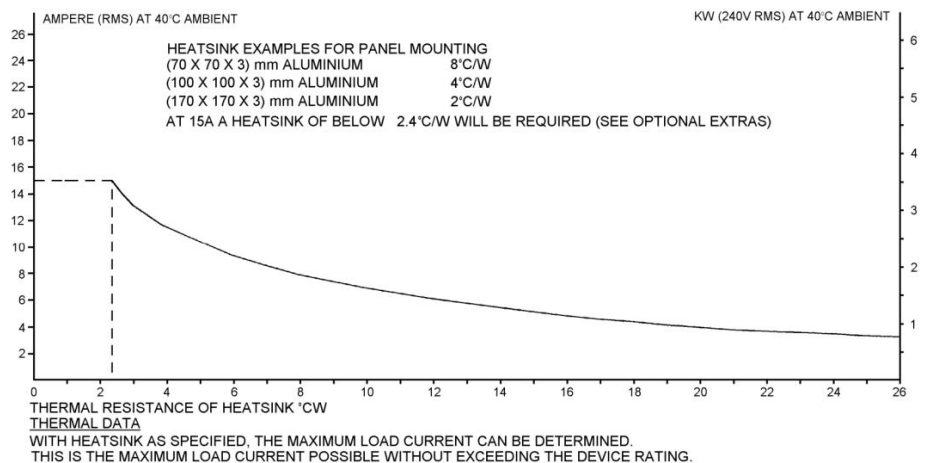

## Fusing

It is recommended to use semiconductor (fast acting) type fuses or circuit breakers (Semiconductor - MCB) for unit protection. On initial switch on some loads may need an increased Factor of Safety (F of S) for unit and/or device protection.