



UNDER CONTROL

Suppliers of Heating Elements and
Temperature Control Solutions

Gas Interlock System GICS5921



undercontrol.co.uk

GAS INTERLOCK PANEL GICS5921



Installation & Operating Instructions

We are pleased to introduce our new Gas Interlock Controller. The GICS5921 is a gas interlock panel with a much smaller footprint. The Interlock System ensures that the gas supply to an appliance is only allowed if the ventilation levels are maintained with acceptable levels. This protects the area from dangerous gas build-up and isolates it, should the commercial kitchen ventilation system not operate within predetermined levels. The gas interlock system GICS5921 fully meets the requirements of CE and BS6173. The cost of ownership is low compared to similar systems manufactured by others on the market.

Usage

- Equipment using natural gas or LPG in hotels, restaurants, takeaway outlets, mobile catering units etc.
- If you have a power-operated flue system for a gas appliance in your commercial kitchen. The British regulation BS6173 states that you should install a safety-lock system.
- This is a requirement if a new ventilation or extraction system is fitted
- A new gas-line pipework or kitchen layout
- Any category B appliance such as combi-oven, grills, griddles, and fryers. This should also be fitted to existing layouts should there not be one present.

Installation & Operating Instructions

ABOUT

Our design encompasses beauty and technology with an innovative design. The unit controls the gas valve by sensing the operation of the extraction and inlet ventilation system fans. This is done by sensing the fan's current using internal current sensors.

Features

- Clear digital LED display
- Current sensing up to 15A
- Special button config press for commissioning access.
- Simple wiring commissioning.
- Emergency stop button.

Installation

- Installation should be carried out by a qualified and competent Electrical Engineer.
- Install the GICS5921 in a clean dry environment and away from excess heat above 50 deg C.
- The GICS5921 should be installed in a safe position that will protect the unit from being damaged. It should also be positioned in an easily accessible area. If this is not possible then additional emergency stop gas shut-off buttons should be fitted.

1. Indicator Lights

The controllers warning lights indicate:

- (1) EXTRACT FAN, normal/ERROR, alarm after 10 sec delay.
- (2) INLET FAN normal/ERROR, alarm after 10 sec delay.
- (3) VALVE is OPEN/CLOSE.

2. Description of buttons

(1) Red Power button stops/starts operation; it also exits from any parameter.

(2) SET: Enters the current sensor to set the alarm value.

(3) SEL: Selects the correct current sensor for setting.

(4) UP: For adjusting the current sensor trigger point up.

(5) DOWN: For adjusting the current sensor trigger point down.

(6). EMERGENCY STOP: closes the gas valve in an emergency.

When this button is pressed, the valve closes immediately without any fault detection, "Emergency Stop" will be displayed on the screen and an audible alarm will sound.

When pressed again, the controller goes into the standby "Start-up" mode, the warning is removed.

3. Warning message

The following error messages display the fault. The warning message error codes will be shown in turn every two seconds as below:

Warning message	
ERROR CURRENT IN	value is lower than the set "val", valve closed.
ERROR CURRENT OUT	value is lower than the set "val", valve closed.

4. SETUP

To enter the setting mode, ensure the unit is displaying "startup" (press the on/off button if not) Long press SET and SEL for 3 seconds to gain access to the setting parameters.

Settings

- Press SET to select the extract or Inlet fan to be set.
- Press Up or Down to turn the sensor off or on (If only one sensor is used, turn the other off to prevent an error alarm)
- Press SEL to select that parameter.
- Press UP or DOWN buttons to change the sensor's trigger point.

Note: The sensor's trigger point should be typically set 10% lower than the fan speed set point indicated by the value reading.

- Press the red ON/OFF button to exit the parameter. "Startup" should be displayed.
- Press the red ON/OFF button to start the GICS5921

Errors

- If the units shows "Error Extract Fan" or "Error Inlet fan" then the fan is running slower than the current sensors trigger point. Turn the fan speed controller up or change the current sensors trigger point
 - The unit shows "Emergency stop" the unit has closed the solenoid valve via the emergency button being pressed or the separately wired emergency stop button.
- Reset buttons by pressing them, unit will then display "start up", press the red start button again.

5. Wiring diagram (GICS 5921)

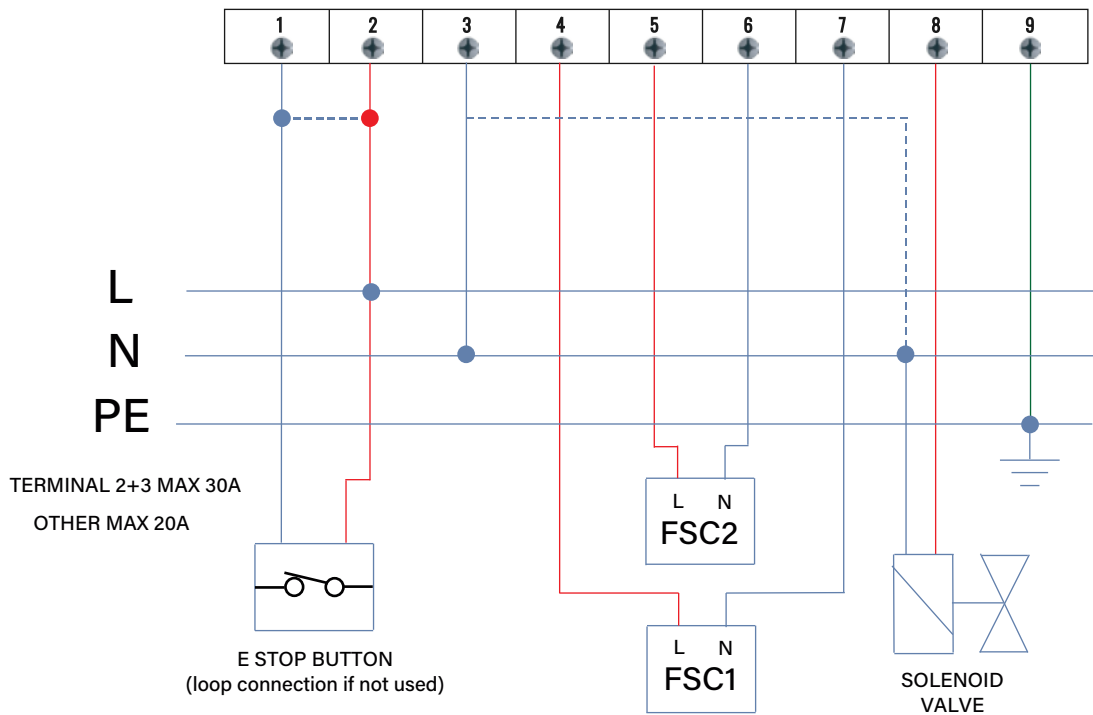

6. GICS5921 Dimension

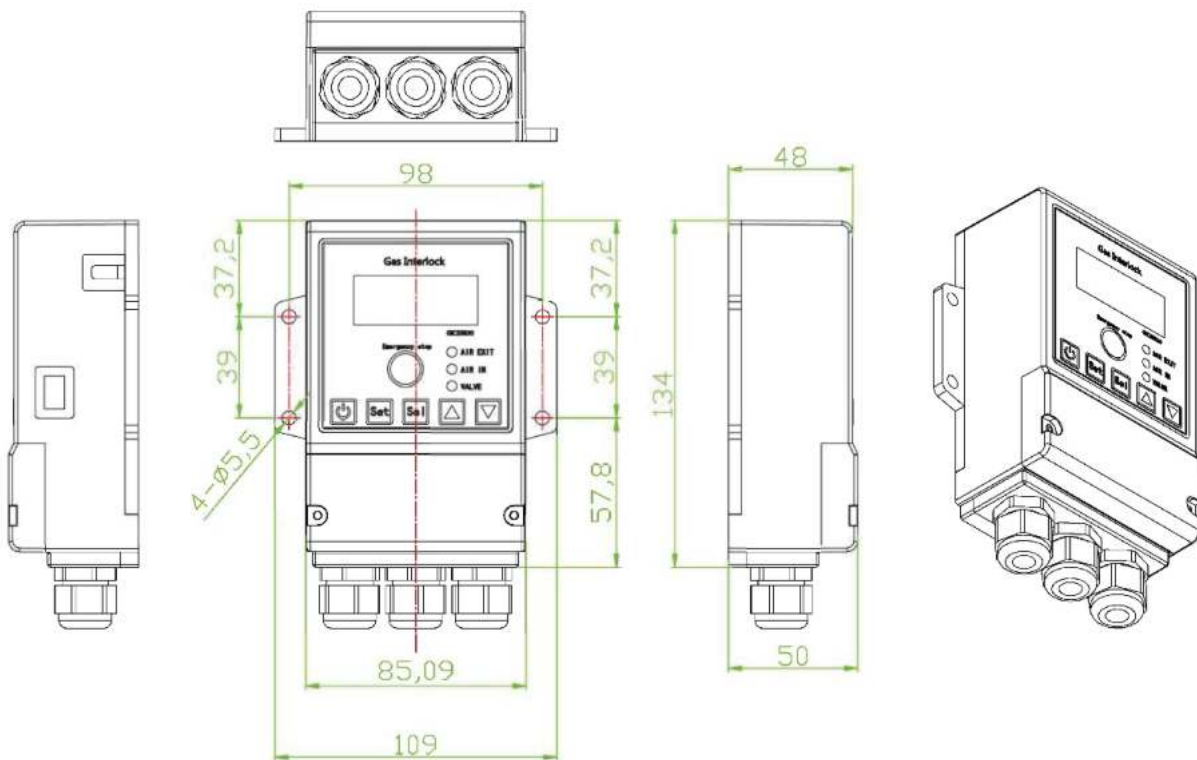

Wiring Connections

Live 240VAC Supply: Terminal 2
 Neutral 240VAC Supply: Terminal 3
 Earth: Terminal 9
 Emergency Stop Button: Terminals 1 & 2
 (loop connection if not used)

Fan speed controller 1: Live to 4 and Neutral to 7
 Fan speed controller 2: Live to 5 and Neutral to 6
 Solenoid valve: Live to 8 and Neutral to 3